

### Features

- ➔ 5 - 4000MHz
- ➔ 20 dB Gain at 900MHz
- ➔ +18.7 dBm P1dB
- ➔ +34 dBm Output IP3
- ➔ No need bias Resistor
- ➔ Lead-free / Green / RoHS-compliant SOT-89 Package



### Applications

- ➔ Broadband Gain Block
- ➔ Mobile Infrastructure
- ➔ Cellular, PCS, GSM, GPRS
- ➔ WCDMA, WiBro
- ➔ W-LAN / DMB
- ➔ RFID/ Fixed Wireless

### Functional Diagram

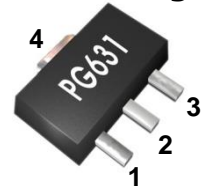

Function	Pin No.
RF IN	1
RF OUT / Bias	3
Ground	2,4

### Description

The PG631 is a high performance InGaP HBT MMIC Amplifier and consists of Darlington pair amplifiers. The amplifier features high linear performance, wideband operation and high reliability. The PG631 designed to enable to stable performance over temperature using an internal active bias of temperature compensated circuit. The PG631 operates from a single voltage supply and requires only two DC-blocking capacitors and a bias inductor for operation. A bias resistor is not required allowing the device to be biased directly from a +5V supply voltage. The device is a general purpose buffer amplifier that offers high dynamic range in a low cost surface-mountable plastic SOT-89 packages. All devices are 100% RF and DC tested.

### Specifications

Symbol	Parameters	Units	Freq.	Min.	Typ.	Max.
S21	Gain	dB	75 MHz		20.8	
			900 MHz		20.2	
			1900 MHz		18.7	
			2300 MHz		17.8	
			2600 MHz		17.0	
S11	Input Return Loss	dB	75 MHz		-24	
			900 MHz		-18	
			1900 MHz		-17	
			2300 MHz		-13	
			2600 MHz		-12	
S22	Output Return Loss	dB	75 MHz		-10	
			900 MHz		-11	
			1900 MHz		-11	
			2300 MHz		-10	
			2600 MHz		-10	
P1dB	Output Power @1dB compression	dBm	75 MHz		18.6	
			900 MHz		18.8	
			1900 MHz		18.8	
			2300 MHz		18.0	
			2600 MHz		17.5	
OIP3	Output Third Order intercept	dBm	75 MHz		34.4	
			900 MHz		34.2	
			1900 MHz		32.6	
			2300 MHz		30.8	
			2600 MHz		30.0	
NF	Noise Figure	dB	75 MHz		4.0	
			900 MHz		3.7	
			1900 MHz		3.8	
			2300 MHz		4.0	
			2600 MHz		4.1	
V / I	Device voltage / current	V/mA			5.0/68	
Rth	Thermal Resistance	°C/W			73	

Test Conditions : T=25°C, Supply Voltage=+5V, 50ohm System, OIP3 measured with two tones at an output power of 0dBm/tone separated by 1MHz.

**Typical RF Performance for 1.9GHz Tuned Application Circuit**  
Supply Bias Voltage = 5V, Current= 68mA

Frequency	MHz	500	900	1500	1900	2300	2600	3000
S21	dB	20.4	20.3	19.5	18.8	18.0	17.3	16.3
S11	dB	-14	-19	-21	-18	-14	-13	-12
S22	dB	-8	-12	-13	-12	-11	-11	-11
P1dB	dBm	19.0	18.9	19.1	19.0	18.2	17.6	16.6
OIP3	dBm	34.0	34.3	34.0	32.8	31.0	30.0	29.5
Noise Figure	dB	3.8	3.6	3.6	3.8	4.0	4.1	4.3

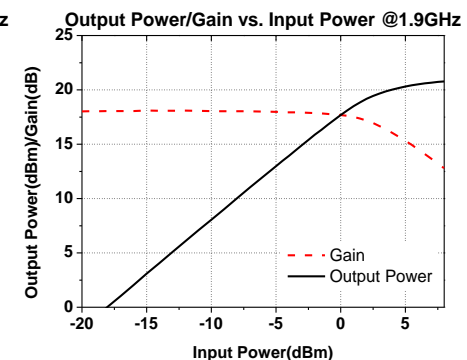
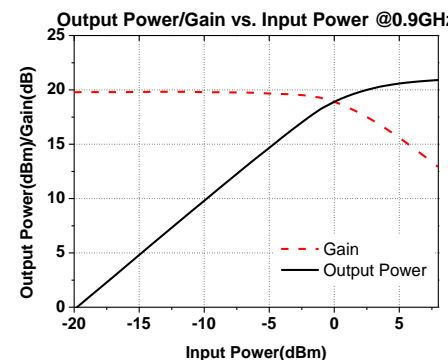
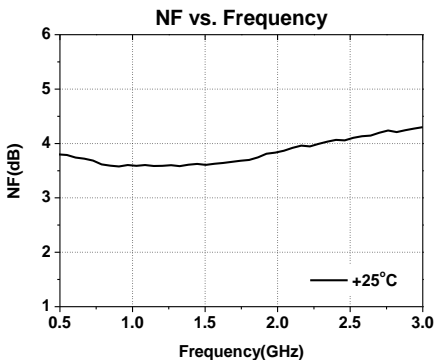
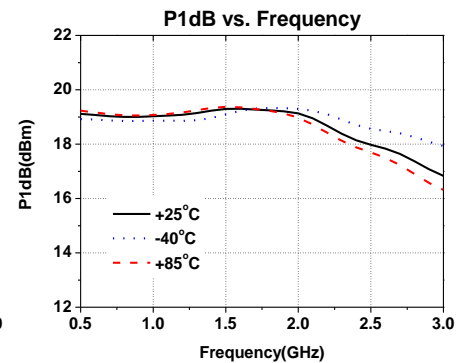
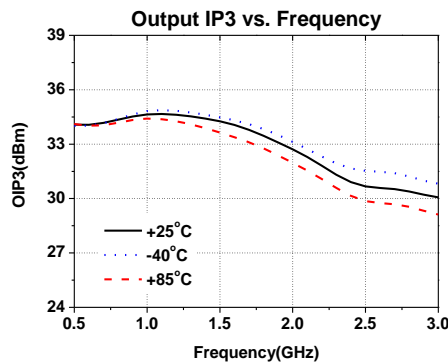
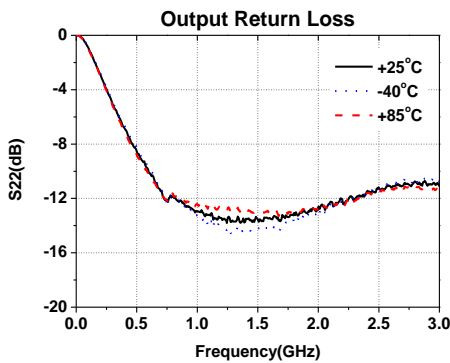
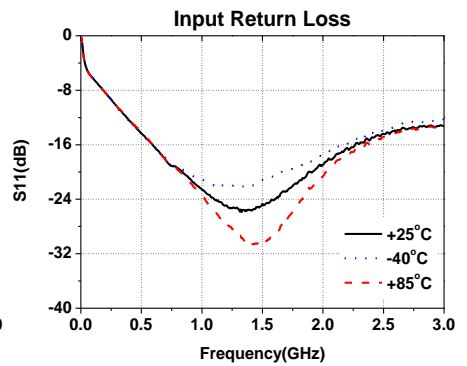
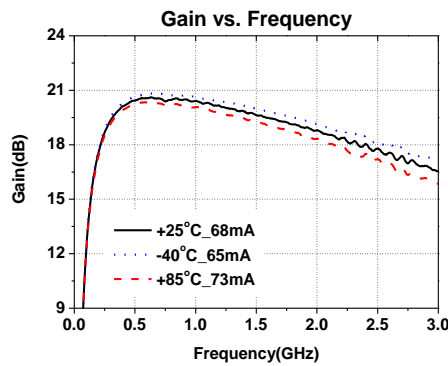
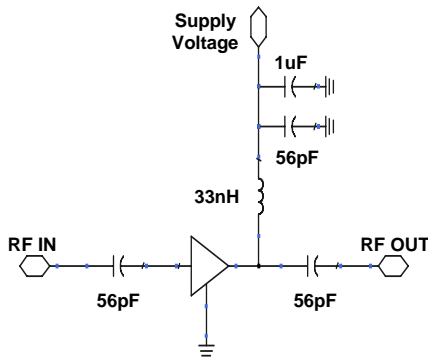

**Typical RF Performance for 50 – 500MHz Tuned Application Circuit**  
Supply Bias Voltage = 5V, Current= 67mA

Frequency	MHz	75	125	300	500
S21	dB	20.8	20.7	20.5	20.4
S11	dB	-25	-27	-30	-28
S22	dB	-10	-11	-11	-11
P1dB	dBm	18.7	18.7	18.8	18.7
OIP3(@0dBm)	dBm	34.5	34.7	34.5	34.8
Noise Figure	dB	4.0	4.1	4.3	4.3

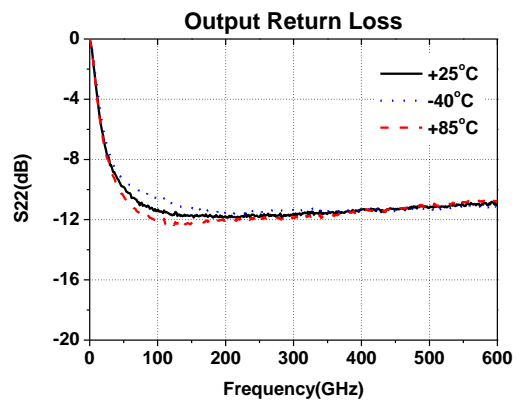
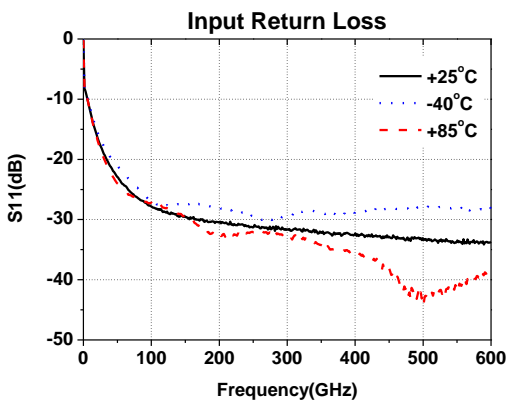
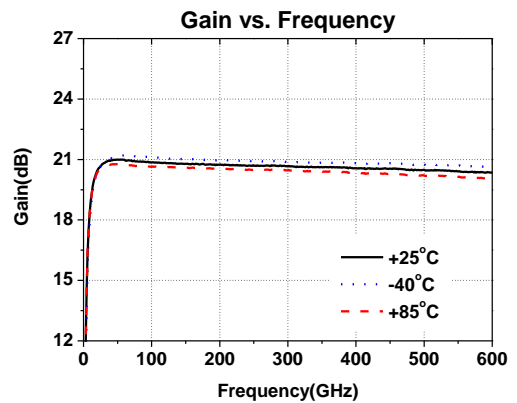
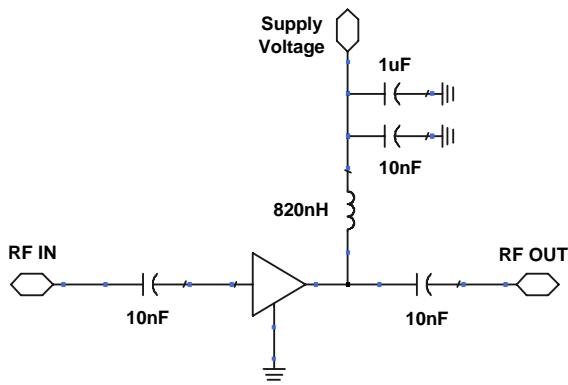

### Absolute Maximum Ratings

Parameter	Rating	Unit
Device Voltage	+5.5	V
Device Current	150	mA
RF Power Input	8	dBm
Storage Temperature	-55 to +125	°C
Ambient Operating Temperature	-40 to +85	°C
Junction Temperature for >10 <sup>6</sup> hours MTF	187	°C

Operation of this device above any of these parameters may cause permanent damage.



### Lead-free / RoHS Compliant / Green SOT-89 Package Outline

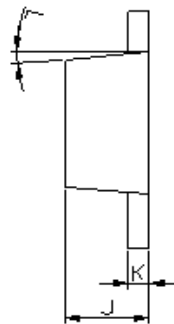
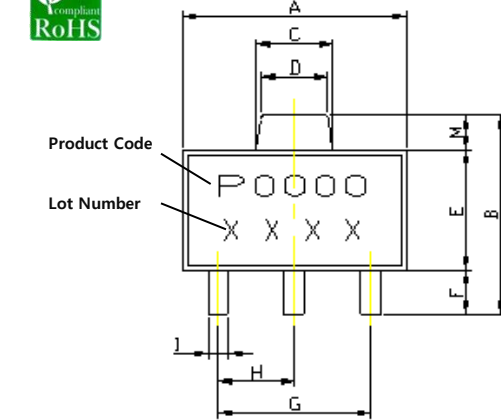

REF	DIMENSIONS Millimeters	
	Min.	Max.
A	4.40	4.60
B	4.05	4.25
C	1.50	1.70
D	1.30	1.50
E	2.40	2.60
F	0.89	1.20
G	3.00 REF.	
H	1.50 REF.	
I	0.40	0.52
J	1.40	1.60
K	0.35	0.41
L	5° TYP.	
M	0.70 REF.	

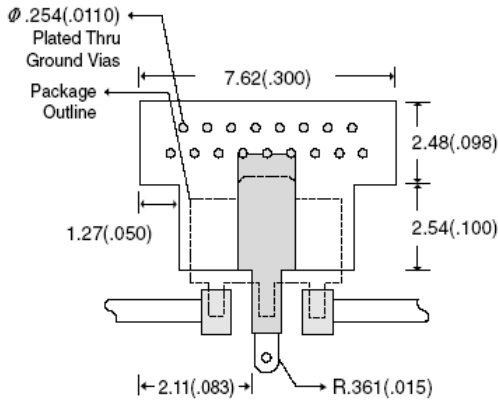

### ESD / MSL Ratings

1. ESD sensitive device. Observe Handling Precautions.
2. ESD Rating : Class 2(Passes at 2000V min.) Human Body Model (HBM), JESD22-A114
3. ESD Rating : Class IV (Passes at 1000V min.) Charged Device Model (CDM), JESD22-C101
4. MSL (Moisture Sensitive Level) Rating : Level 1 at +260°C Convection reflow, J-STD-020

### Evaluation Board Layout (4x4)

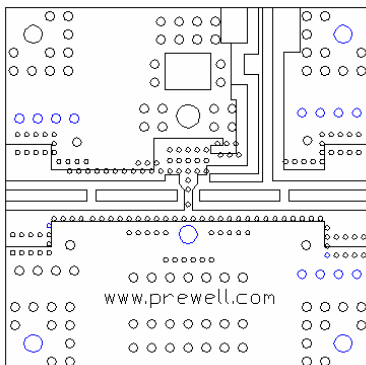

### Mounting Instructions

1. Use a large ground pad area with many plated through-holes as shown.
2. We recommend 1 oz copper minimum.
3. Measurement for our data sheet was made on 0.8mm thick FR-4 Board.
4. Add as much copper as possible to inner and outer layers near the part to ensure optimal thermal performance.
5. RF trace width depends on the board material and construction.
6. Add mounting screws near the part to fasten the board to a heatsink.