

PK833

40-2200MHz CATV Amplifier



Features

- 40 - 2200MHz
- 17dB Gain at 2140MHz
- CSO 63dBc @+30dBmV
- CTB 73dBc @+30dBmV
- NF 2.3dB
- Single 5V Supply Voltage
- Lead-free / Green / RoHS-compliant SOT-89 Package



Applications

- Headend Driver Amplifier
- Predriver Amplifier
- Line Driver Amplifier
- Optic Transceiver Application
- Active Splitter
- MOCA
- FTTH Application
- Satellite Application

Functional Diagram

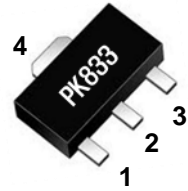

Function	Pin No.
RF IN	1
RF OUT / Bias	3
Ground	2,4

Description

The PK833 is a high performance p-HEMT MMIC Amplifier that is internally matched to 75Ω input/output. The amplifier features excellent gain flatness, broadband, high CSO/CTB performance, high reliability, low noise as an CATV amplifier. The PK833 operates from a single supply voltage and require minimal external Components. The device amplifier offers high dynamic range in a low cost surface-mountable plastic SOT-89 package. All devices are 100% RF and DC tested.

Specifications

* Test Conditions : T=25°C, Supply Voltage=+5V, 75ohm System

Symbol	Parameters	Units	Min.	Typ.	Max.	Condition
F	Frequency	MHz	40		2200	
S21	Gain	dB		17.1		40 ~ 2200MHz
S11	Input Return Loss	dB	-16	-18		@2140 MHz
S22	Output Return Loss	dB	-18	-20		@2140 MHz
CSO	Composite Second Order	dBc		63		+30dBmV/132ch Flat
CTB	Composite Triple Beat	dBc		73		+30dBmV/132ch Flat
OIP3	Output Third Order Intercept Point	dBm		39.0		Note 1
P1dB	Output Power at 1dB Compression	dBm		20.0		@860 MHz
NF	Noise Figure	dB		2.3		@1600 MHz
I	Current	mA	110	125	140	
Rth	Thermal Resistance	°C/W		15		

Note 1. Two Tones, 1MHz Spacing, +5dBm per Tone at Output

RF Performance for Supply 5V Tuned Application Circuit

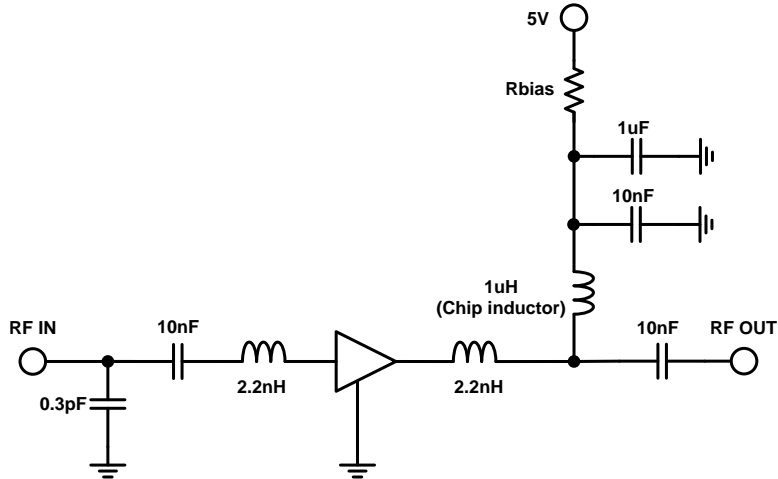

Note 1: Measurement for our datasheet was made on 1.6mm thick FR-4 Board. And 75 ohm microstrip line

5V/ 125mA(Rbias : 0Ω), CSO/CTB Test Condition : 30dBmV/132ch, T=25°C							
Freq.	S21[dB]	S11[dB]	S22[dB]	CSO[dBc]	CTB[dBc]	OIP3[dBm]	NF[dB]
77.25	17.3	-18	-22	-68	-76	40.0	2.3
288.25	17.2	-21	-25	-68	-74	40.0	2.2
328.25	17.2	-20	-24	-66	-74	40.0	2.2
448.25	17.2	-20	-24	-63	-74	39.5	2.2
543.25	17.2	-19	-25	-65	-73	39.5	2.2
743.25	17.2	-18	-27	-65	-73	39.5	2.0
855.25	17.2	-18	-30	-71	-72	39.0	2.0

5V/ 110mA(Rbias : 4.7Ω), CSO/CTB Test Condition : 30dBmV/132ch, T=25°C							
Freq.	S21[dB]	S11[dB]	S22[dB]	CSO[dBc]	CTB[dBc]	OIP3[dBm]	NF[dB]
77.25	17.3	-18	-22	-62	-75	38.5	2.3
288.25	17.2	-21	-25	-63	-74	39.5	2.3
328.25	17.2	-20	-24	-63	-74	39.0	2.2
448.25	17.2	-20	-24	-61	-74	39.0	2.2
543.25	17.2	-19	-25	-63	-73	39.0	2.2
743.25	17.2	-18	-27	-63	-73	39.0	2.0
855.25	17.2	-18	-30	-70	-72	39.0	2.0

PK833

40-2200MHz CATV Amplifier

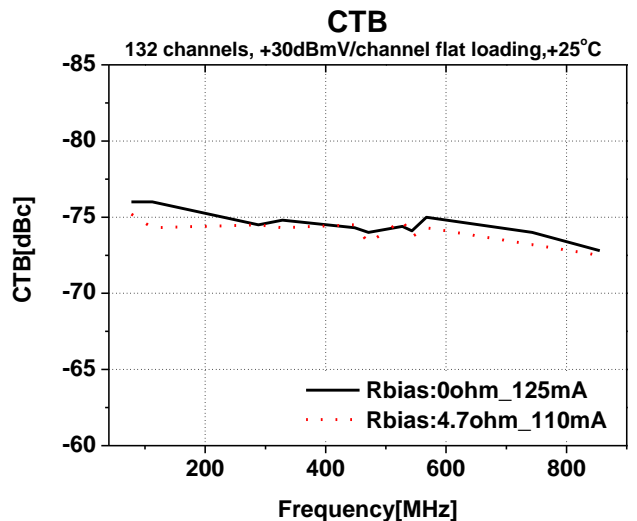
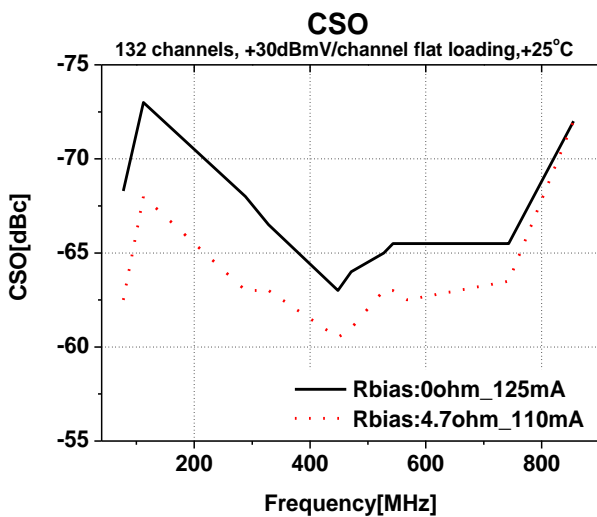
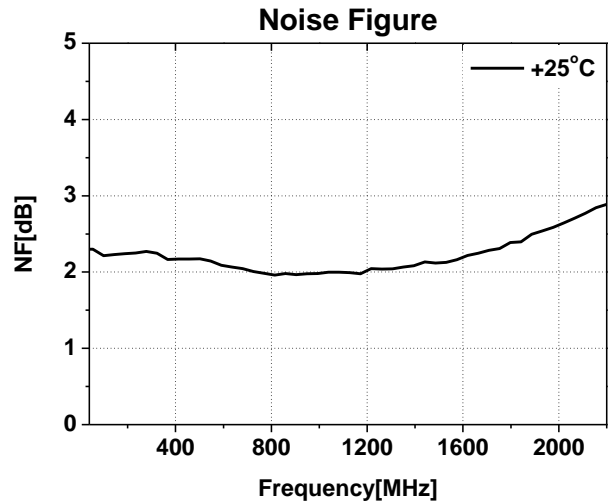
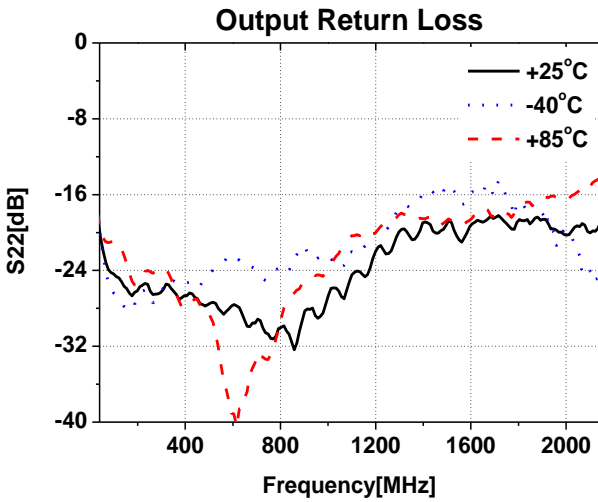
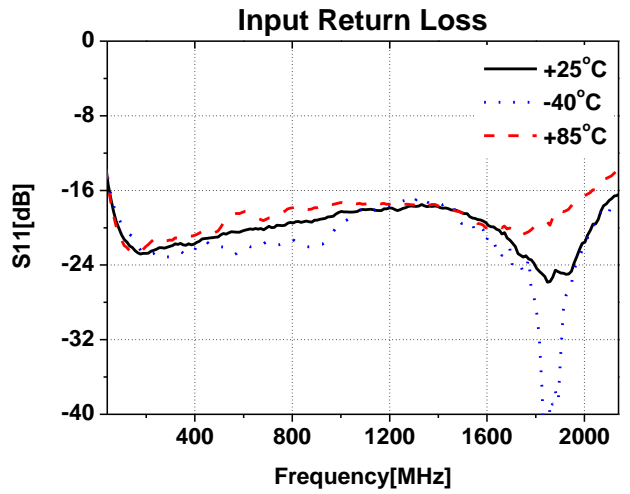
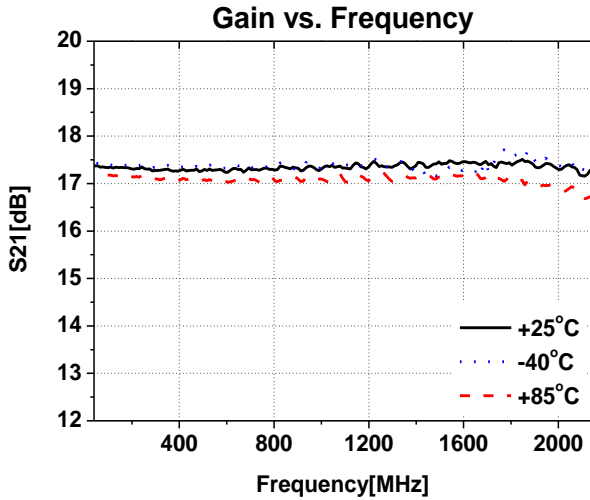

PK833

40-2200MHz CATV Amplifier



RF Performance for Supply 8V Tuned Application Circuit

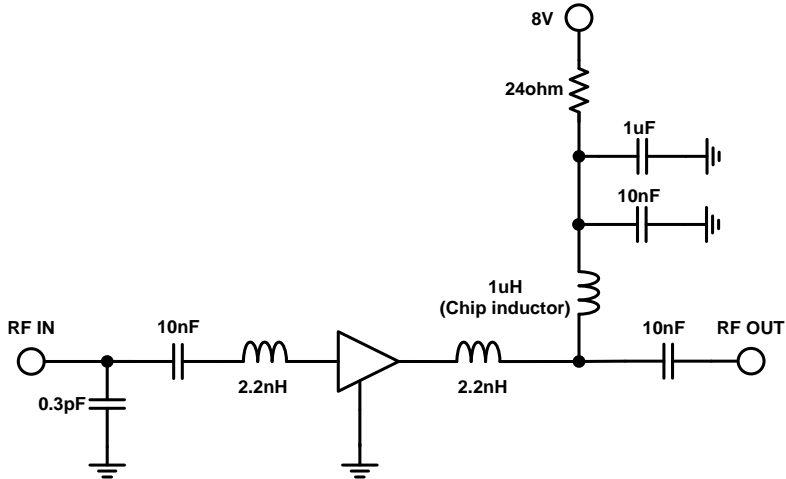

Note 1: Measurement for our datasheet was made on 1.6mm thick FR-4 Board. And 75 ohm microstrip line

8V/ 125mA(Rbias : 24Ω), CSO/CTB Test Condition : 30dBmV/132ch, T=25°C							
Freq.	S21[dB]	S11[dB]	S22[dB]	CSO[dBc]	CTB[dBc]	OIP3[dBm]	NF[dB]
77.25	17.3	-18	-22	-64	-75	41.0	2.3
288.25	17.2	-21	-25	-66	-74	40.0	2.2
328.25	17.2	-20	-24	-64	-74	41.0	2.2
448.25	17.2	-20	-24	-62	-73	41.0	2.2
543.25	17.2	-19	-25	-64	-73	40.0	2.2
743.25	17.2	-18	-27	-64	-72	40.0	2.0
855.25	17.2	-18	-30	-71	-72	40.0	2.0

Absolute Maximum Ratings

Parameter	Rating	Unit
Device Voltage	+9	V
Device Current	180	mA
RF Power Input	3	dBm
Storage Temperature	-55 to +150	°C
Ambient Operating Temperature	-40 to +85	°C
Junction Temperature	160	°C

Operation of this device above any of these parameters may cause permanent damage.

ESD / MSL Ratings

1. ESD sensitive device. Observe Handling Precautions.
2. ESD Rating : Class 1B (Passes at 500V min.) Human Body Model (HBM), JESD22-A114
3. ESD Rating : Class IV (Passes at 1000V min.) Charged Device Model (CDM), JESD22-C101
4. MSL (Moisture Sensitive Level) Rating : Level 3 at +260°C Convection reflow, J-STD-020

Evaluation Board Layout (40x40)

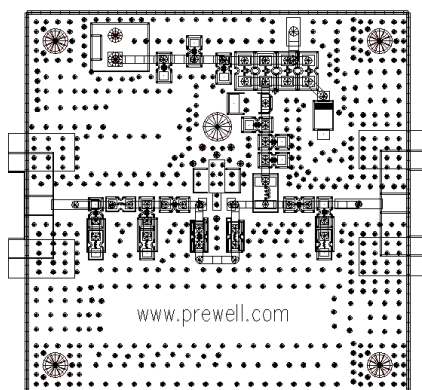

Mounting Instructions

1. Use a large ground pad area with many plated through-holes as shown.
2. We recommend 1 oz copper minimum.
3. Measurement for our data sheet was made on 1.6mm thick FR-4 Board.
4. Add as much copper as possible to inner and outer layers near the part to ensure optimal thermal performance.
5. RF trace width depends on the board material and construction.
6. Add mounting screws near the part to fasten the board to a heatsink.