

Features

- ➔ DC - 3000MHz
- ➔ 18.0 dB Gain at 0.9GHz
- ➔ +13 dBm P1dB
- ➔ +27.0 dBm Output IP3
- ➔ Single Voltage Supply
- ➔ Lead-free / Green / RoHS-compliant SOT-363 Package

Applications

- ➔ Broadband Gain Block
- ➔ Mobile Infrastructure
- ➔ Cellular, PCS, GSM, GPRS, WCDMA, WiBro, WiMAX
- ➔ W-LAN / DMB / ISM
- ➔ CATV / DBS
- ➔ RFID / Fixed Wireless

Functional Diagram

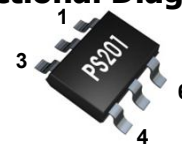

* Marking : 21C

Function	Pin No.
RF IN	3
RF OUT / Bias	6
Ground	1,2,4,5

Description

The PS201-63 is a high performance InGaP HBT MMIC Amplifier and consists of Darlington pair amplifiers. The amplifier features high linear performance, wideband operation, and high reliability. The PS201-63 operates from a single voltage supply and requires only two DC-blocking capacitors, a bias resistor and an inductor for operation. The device is a general purpose buffer amplifier that offers high dynamic range in a low cost surface-mountable plastic SOT-363 packages.

Specifications

Symbol	Parameters	Units	Freq.	Min.	Typ.	Max.
S21	Gain	dB	75 MHz 900 MHz 1900 MHz 2300 MHz		19.4 18.4 17.1 16.5	
S11	Input Return Loss	dB	75 MHz 900 MHz 1900 MHz 2300 MHz		-13 -12 -13 -14	
S22	Output Return Loss	dB	75 MHz 900 MHz 1900 MHz 2300 MHz		-11 -12 -12 -11	
P1dB	Output Power @1dB compression	dBm	75 MHz 900 MHz 1900 MHz 2300 MHz		14.0 13.5 11.0 9.8	
OIP3	Output Third Order intercept	dBm	75 MHz 900 MHz 1900 MHz 2300 MHz		29.0 27.0 23.1 21.2	
NF	Noise Figure	dB	75 MHz 900 MHz 1900 MHz 2300 MHz		2.4 2.5 2.5 2.6	
V / I	Device voltage / current	V/mA			3.45/35	
Rth	Thermal Resistance	°C/W			92	
Tj	Junction Temperature	°C			98	

Test Conditions : T=25°C, Supply Voltage=+4.5V, Rbias=28ohm, 50ohm System, OIP3 measured with two tones at an output power of -5dBm/tone separated by 1MHz.

<http://www.prewell.com>

Typical RF Performance for 900MHz Tuned Application Circuit
Supply Bias Voltage = 4.5V, R(bias)= 28 ohm, Current= 35mA

Frequency	MHz	500	900	1500	1900	2300	3000
S21	dB	19.0	18.5	17.8	17.3	16.8	14.9
S11	dB	-13	-12	-12	-13	-15	-13
S22	dB	-12	-12	-12	-12	-11	-10
P1dB	dBm	14.0	13.6	12.4	11.1	9.8	7.7
OIP3	dBm	28.1	27.1	24.8	23.3	21.5	19.1
Noise Figure	dB	2.5	2.5	2.5	2.5	2.6	2.7

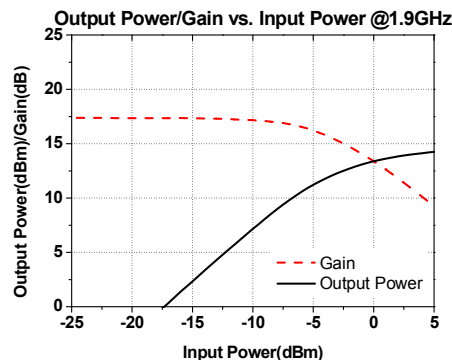
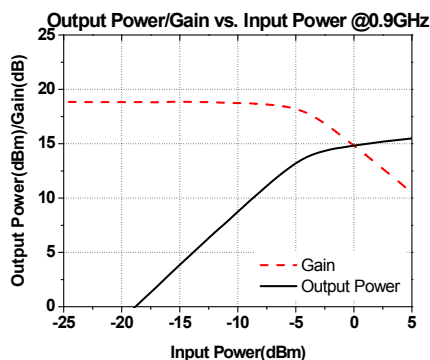
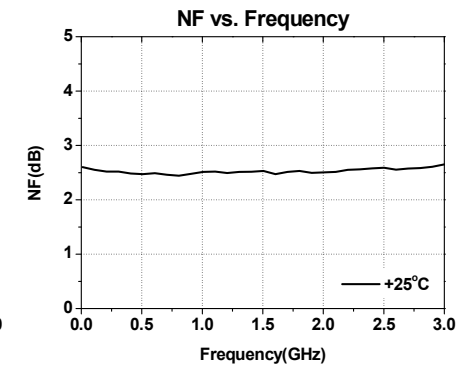
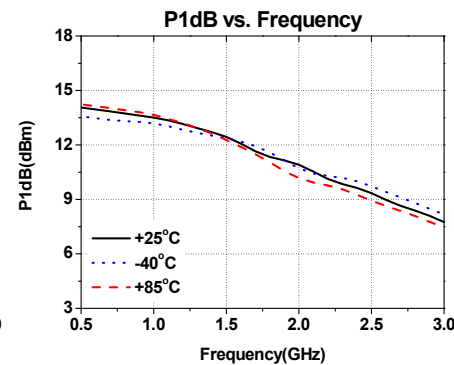
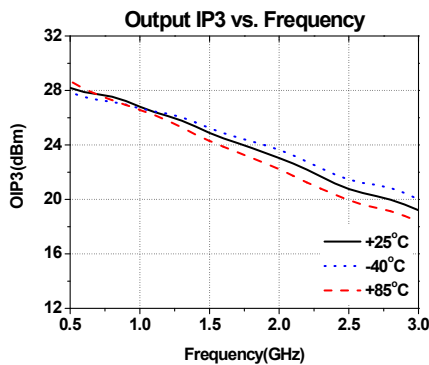
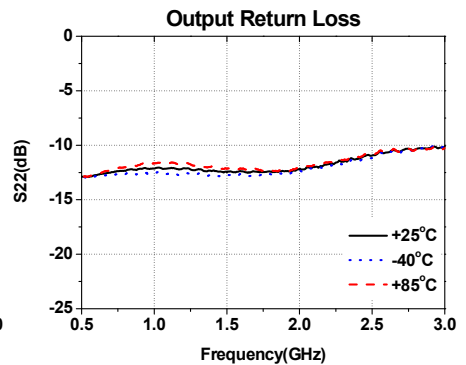
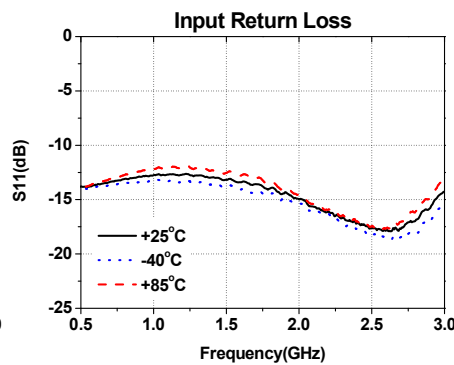
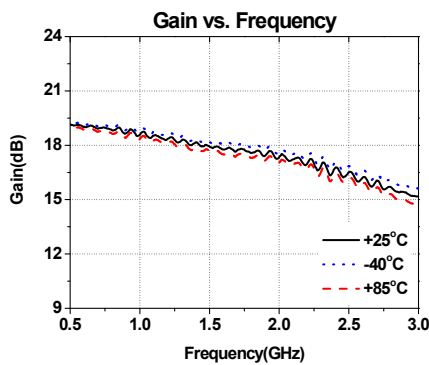

900MHz Tuned Application Circuit

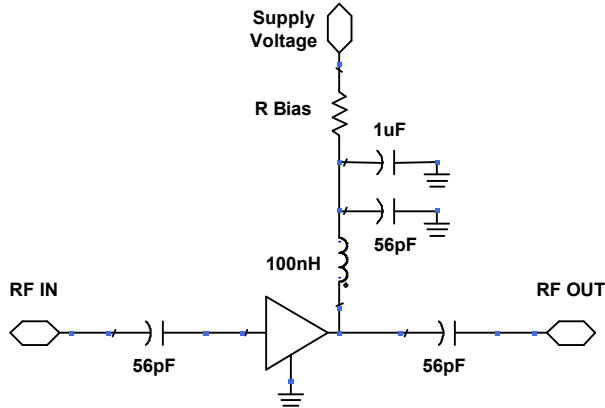

Recommended Bias Values

Supply Voltage	R bias Value	Size
4.5 V	28.0 Ω	0805
5 V	42.5 Ω	1210
6 V	71.0 Ω	1210
7 V	99.0 Ω	2010
8 V	128.0 Ω	2010
10 V	185.0 Ω	2010
12 V	242.0 Ω	2512

Typical RF Performance for 50 -500MHz Tuned Application Circuit

Supply Bias Voltage = 4.5V, R(bias)= 28ohm, Current= 35mA

Frequency	MHz	75	125	300	500
S21 : Gain	dB	19.4	19.4	19.2	19.0
S11 : Input Return Loss	dB	-13	-13	-13	-12
S22 : Output Return Loss	dB	-11	-12	-12	-11
Output P1dB	dBm	14	14	14	14
Output IP3 @-5dBm	dBm	29.0	29.6	29.4	28.0
Noise Figure	dB	2.4	2.4	2.4	2.4

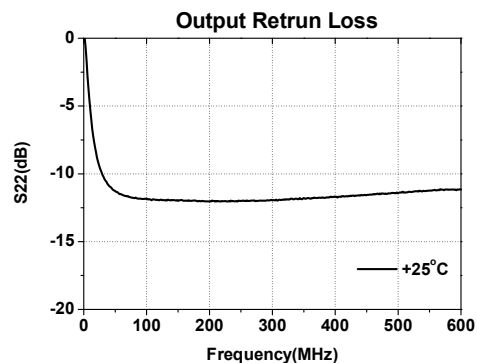
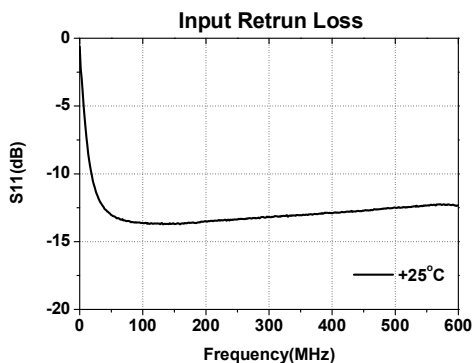
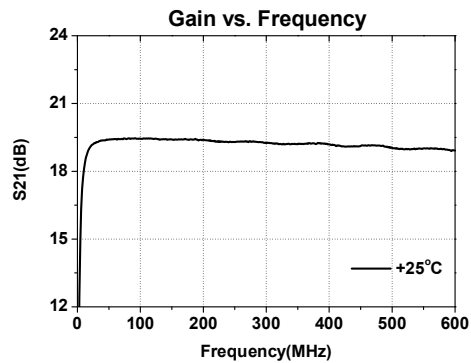
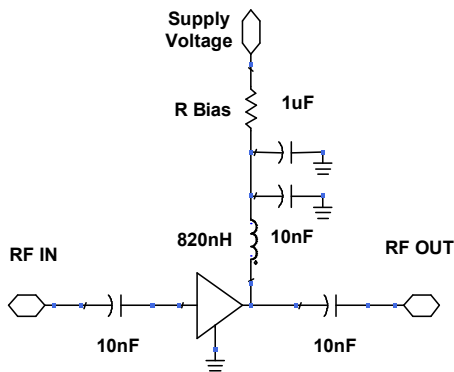

Absolute Maximum Ratings

Parameter	Rating	Unit
Supply Voltage	+8	V
Supply Current	150	mA
RF Power Input	5	dBm
Storage Temperature	-55 to +125	°C
Ambient Operating Temperature	-40 to +85	°C

Operation of this device above any of these parameters may cause permanent damage.

Lead-free / RoHS Compliant / Green SOT-363 Package Outline

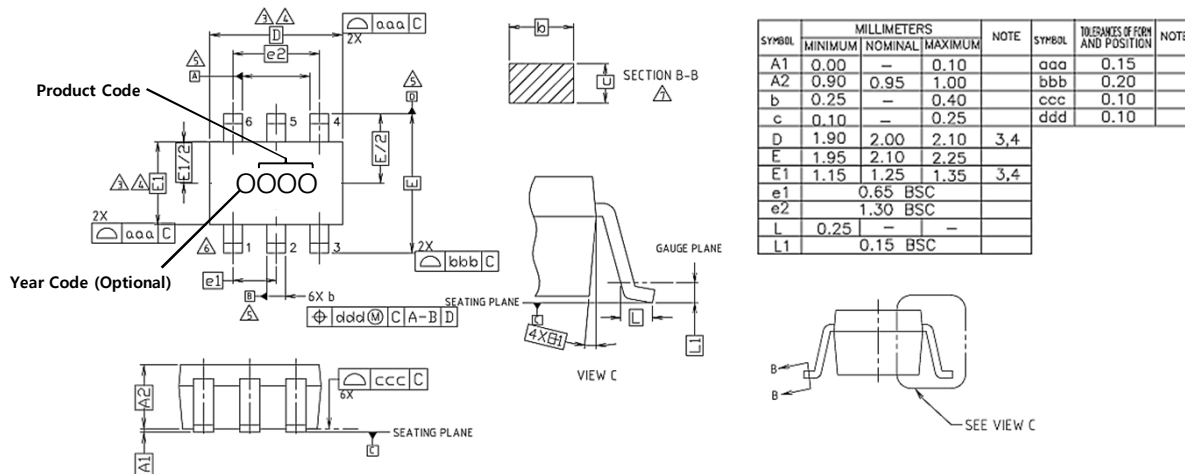

Land Pattern

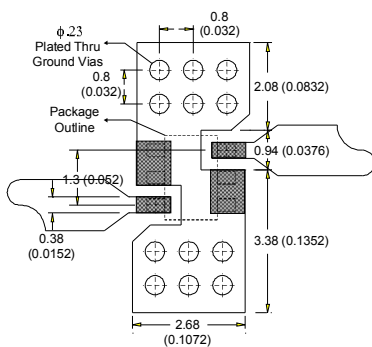

Evaluation Board Layout (4x4)

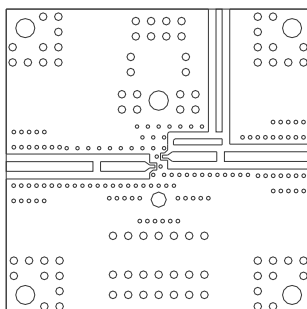

ESD / MSL Ratings

- ESD sensitive device. Observe Handling Precautions.
- ESD Rating : Class 2(Passes at 2000V min.) Human Body Model (HBM), JESD22-A114
- ESD Rating : Class IV (Passes at 1000V min.) Charged Device Model (CDM), JESD22-C101
- MSL (Moisture Sensitive Level) Rating : Level 3 at +260°C Convection reflow, J-STD-020

Mounting Instructions

- Use a large ground pad area with many plated through-holes as shown.
- We recommend 1 oz copper minimum.
- Measurement for our data sheet was made on 0.8mm thick FR-4 Board.
- Add as much copper as possible to inner and outer layers near the part to ensure optimal thermal performance.
- RF trace width depends on the board material and construction.
- Add mounting screws near the part to fasten the board to a heatsink.

<http://www.prewell.com>