

Features

- 45 - 1000MHz
- 15.0dB Gain at 45MHz
- CSO 63dBc @+25dBmV
- CTB 73dBc @+25dBmV
- NF 4.2dB
- Lead-free / Green / RoHS-compliant SOT-89 Package



Applications

- Headend Driver Amplifier
- Predriver Amplifier
- Line Driver Amplifier
- Optic Transceiver Application
- Active Splitter
- MOCA
- FTTH Application

Functional Diagram

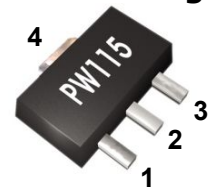

Function	Pin No.
RF IN	1
RF OUT / Bias	3
Ground	2,4

Description

The PW115 is a high performance InGaP HBT MMIC Amplifier and consists of Darlington pair amplifiers with temperature compensation that is internally matched to 75Ω input/output. The amplifier features high linear performance and high reliability as an CATV amplifier and provides stable current variation. The PW115 operates from a single voltage supply and requires minimal external components, a bias resistor and an inductor for operation. The device is a general purpose CATV amplifier that offers high dynamic range in a low cost surface-mountable plastic SOT-89 packages. All devices are 100% RF and DC tested.

Specifications

* Test Conditions : T=25°C, Supply Voltage=+5V, 75ohm System

Symbol	Parameters	Units	Min.	Typ.	Max.	Condition
F	Frequency	MHz	45		1000	
S21	Gain	dB	14.0	15.0	16.0	45 ~ 1000MHz
S11	Input Return Loss	dB	-9	-11		45 ~ 1000MHz
S22	Output Return Loss	dB	-12	-14		45 ~ 1000MHz
CSO	Composite Second Order	dBc		63		+25dBmV/132ch Flat
CTB	Composite Triple Beat	dBc		73		+25dBmV/132ch Flat
OIP3	Output Third Order Intercept Point	dBm		36.5		Note 1
P1dB	Output Power at 1dB Compression	dBm		19.0		
Vo	Output Voltage	dBmV		57.2		Note 2
d2	Second Order Distortion	dBc		63.5		Note 3
NF	Noise Figure	dB		4.2		
I	Current	mA	80	90	100	
Rth	Thermal Resistance	°C/W		78		

Note 1. Two Tones, 1MHz Spacing, +5dBm per Tone at Output

Note 2 $f_p=851.25\text{MHz}$; $V_p=V_o$; $f_q=858.25\text{MHz}$; $V_q=V_o-6\text{dB}$; $f_r=860.25\text{MHz}$; $V_r=V_o-6\text{dB}$; measured at $f_p+f_q-f_r=849.25\text{MHz}$

Note 3 $f_p=55.25\text{MHz}$; $V_p=40\text{dBmV}$; $f_q=805.25\text{MHz}$; $V_q=40\text{dBmV}$, measured at $f_p+f_q=860.5\text{MHz}$

<http://www.prewell.com>

45 - 1000MHz CATV Application Circuit

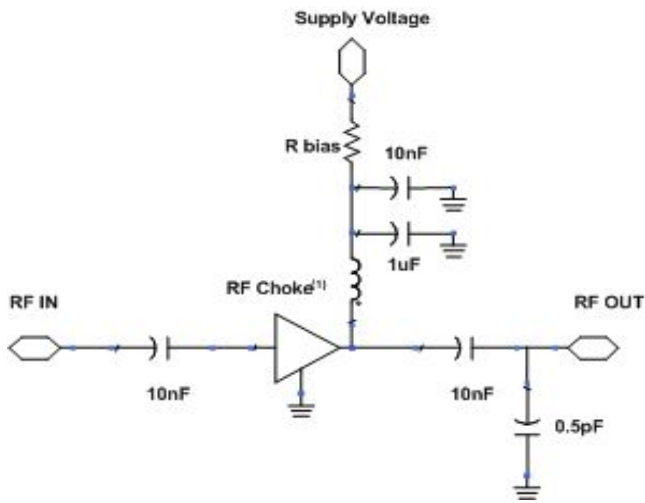

Recommended Bias Values

Supply Voltage	R bias Value	Size
5 V	2.0 Ω	0805
6 V	13.0 Ω	0805
8 V	36.0 Ω	1210
10 V	62.0 Ω	2010
12 V	82.0 Ω	2512

$R_{bias} = (V_s - V_d) / I_d$

1. RF Choke is about 5uH. We recommend that wire of 0.2 phi radius wind 5 turns on toroidal core(size:4.0x1.5x2.0)
2. Measurement for our datasheet was made on 1.6mm thick FR-4 Board. And 75 ohm microstrip line

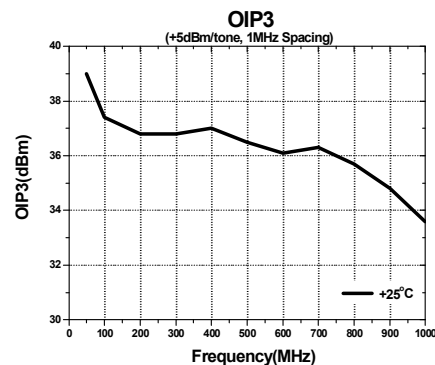
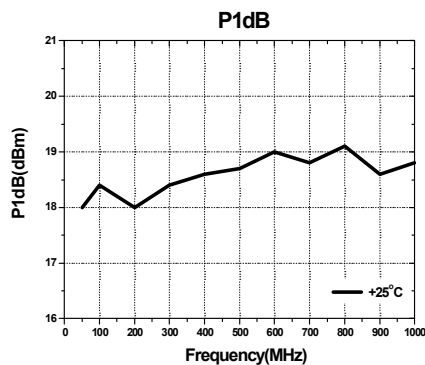
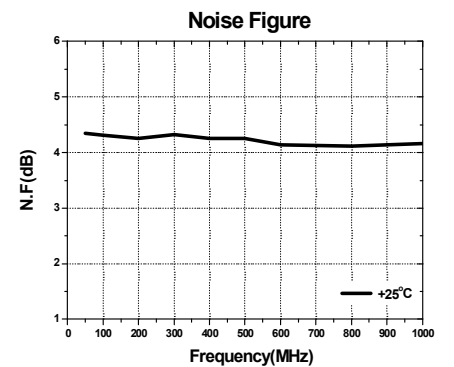
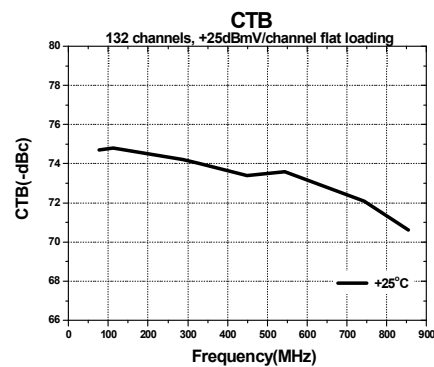
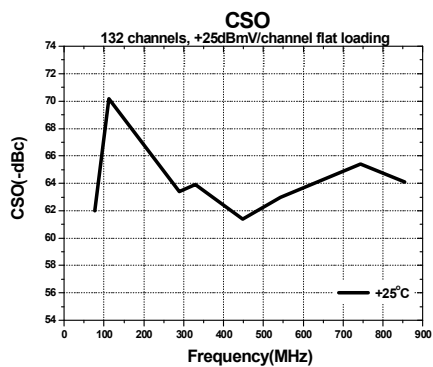
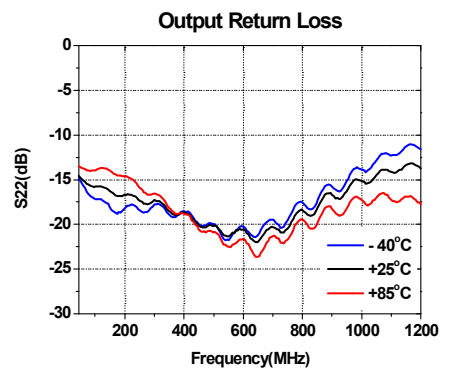
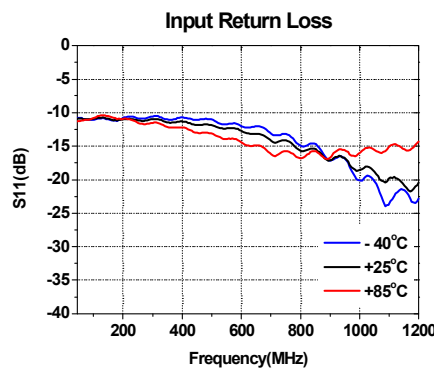
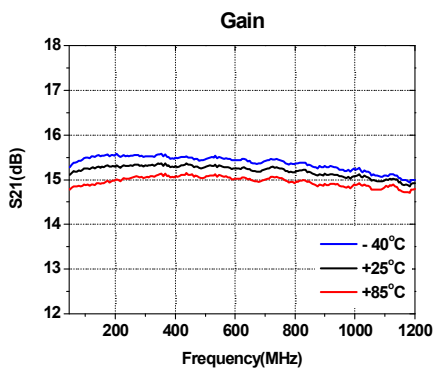

Absolute Maximum Ratings

Parameter	Rating	Unit
Device Voltage	+5	V
Device Current	160	mA
RF Power Input	10	dBm
Storage Temperature	-55 to +125	°C
Ambient Operating Temperature	-40 to +85	°C
Junction Temperature	165	°C

Operation of this device above any of these parameters may cause permanent damage.



Lead-free / RoHS Compliant / Green SOT-89 Package Outline

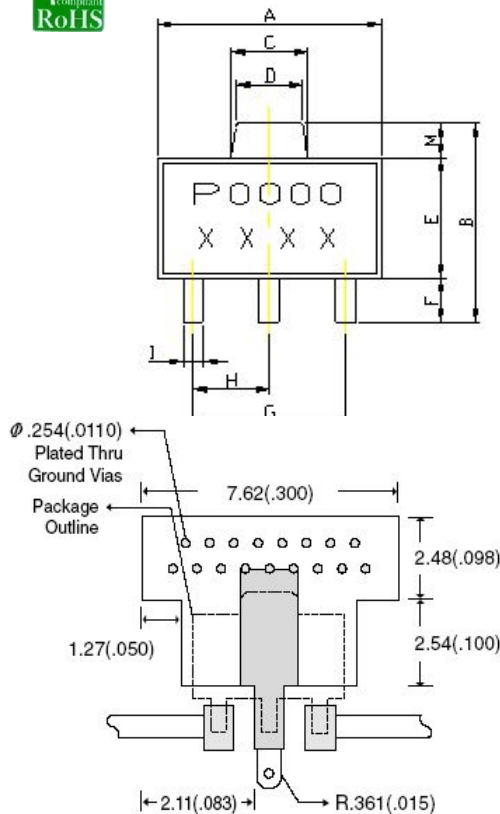

REF	DIMENSIONS	
	Millimeters	
	Min.	Max.
A	4.40	4.60
B	4.05	4.25
C	1.50	1.70
D	1.30	1.50
E	2.40	2.60
F	0.89	1.20
G	3.00 REF.	
H	1.50 REF.	
I	0.40	0.52
J	1.40	1.60
K	0.35	0.41
L	5° TYP.	
M	0.70 REF.	

ESD / MSL Ratings

- ESD sensitive device. Observe Handling Precautions.
- ESD Rating : Class 2(Passes at 2000V min.) Human Body Model (HBM), JESD22-A114
- ESD Rating : Class IV (Passes at 1000V min.) Charged Device Model (CDM), JESD22-C101
- MSL (Moisture Sensitive Level) Rating : Level 3 at +260°C Convection reflow, J-STD-020

Evaluation Board Layout (30x40)

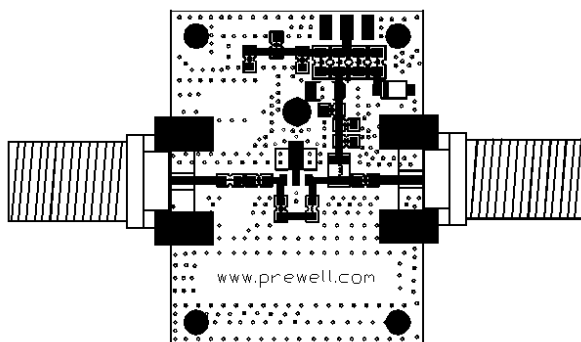

Mounting Instructions

- Use a large ground pad area with many plated through-holes as shown.
- We recommend 1 oz copper minimum.
- Measurement for our data sheet was made on 1.6mm thick FR-4 Board.
- Add as much copper as possible to inner and outer layers near the part to ensure optimal thermal performance.
- RF trace width depends on the board material and construction.
- Add mounting screws near the part to fasten the board to a heatsink.

<http://www.prewell.com>