

### Features

- ➔ DC - 3000MHz
- ➔ 16.7 dB Gain at 0.9GHz
- ➔ +17.6 dBm P1dB
- ➔ +33.5 dBm Output IP3
- ➔ Single Voltage Supply
- ➔ Lead-free / Green / RoHS-compliant SOT-89 Package

### Applications

- ➔ Broadband Gain Block
- ➔ Mobile Infrastructure
- ➔ Cellular, PCS, GSM, GPRS, WCDMA, WiBro
- ➔ W-LAN / DMB
- ➔ CATV / DBS
- ➔ RFID / Fixed Wireless

### Functional Diagram

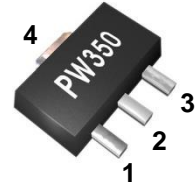

Function	Pin No.
RF IN	1
RF OUT / Bias	3
Ground	2,4

### Description

The PW350 is a high performance InGaP HBT MMIC Amplifier and consists of Darlington pair amplifiers. The amplifier features high linear performance, wideband operation, and high reliability. The PW350 operates from a single voltage supply and requires only two DC-blocking capacitors, a bias resistor and an inductor for operation. The device is a general purpose buffer amplifier that offers high dynamic range in a low cost surface-mountable plastic SOT-89 packages.

### Specifications

Symbol	Parameters	Units	Freq.	Min.	Typ.	Max.
S21	Gain	dB	75 MHz 900 MHz 1900 MHz 2300 MHz 2600 MHz		16.9 16.7 16.4 15.9 15.4	
S11	Input Return Loss	dB	75 MHz 900 MHz 1900 MHz 2300 MHz 2600 MHz		-18 -18 -30 -25 -22	
S22	Output Return Loss	dB	75 MHz 900 MHz 1900 MHz 2300 MHz 2600 MHz		-12 -16 -10 -9 -8	
P1dB	Output Power @1dB compression	dBm	75 MHz 900 MHz 1900 MHz 2300 MHz 2600 MHz		18.5 17.6 16.5 15.7 15.0	
OIP3	Output Third Order intercept	dBm	75 MHz 900 MHz 1900 MHz 2300 MHz 2600 MHz		33.5 33.5 30.5 29 28	
NF	Noise Figure	dB	75 MHz 900 MHz 1900 MHz 2300 MHz 2600 MHz		3.2 3.3 3.5 3.6 3.6	
V / I	Device voltage / current	V/mA			4.84/58	
Rth	Thermal Resistance	°C/W			68	

Test Conditions : T=25°C, Supply Voltage=+6V, Rbias=20ohm, 50ohm System, OIP3 measured with two tones at an output power of +3dBm/tone separated by 1MHz.

### Typical RF Performance for 1.9GHz Tuned Application Circuit

Supply Bias Voltage = 6V, R(bias)= 20 ohm, Current= 58mA

Frequency	MHz	500	900	1500	1900	2300	2600	3000
S21	dB	16.4	16.7	16.6	16.4	15.9	15.4	14.5
S11	dB	-12	-18	-26	-34	-26	-22	-22
S22	dB	-10	-17	-14	-11	-9	-8	-8
P1dB	dBm	15.8	17.6	17.1	16.5	15.9	15.0	13.3
OIP3	dBm	32.6	33.5	31.8	30.8	29.4	28.3	27.1
Noise Figure	dB	3.4	3.3	3.4	3.5	3.6	3.6	3.7

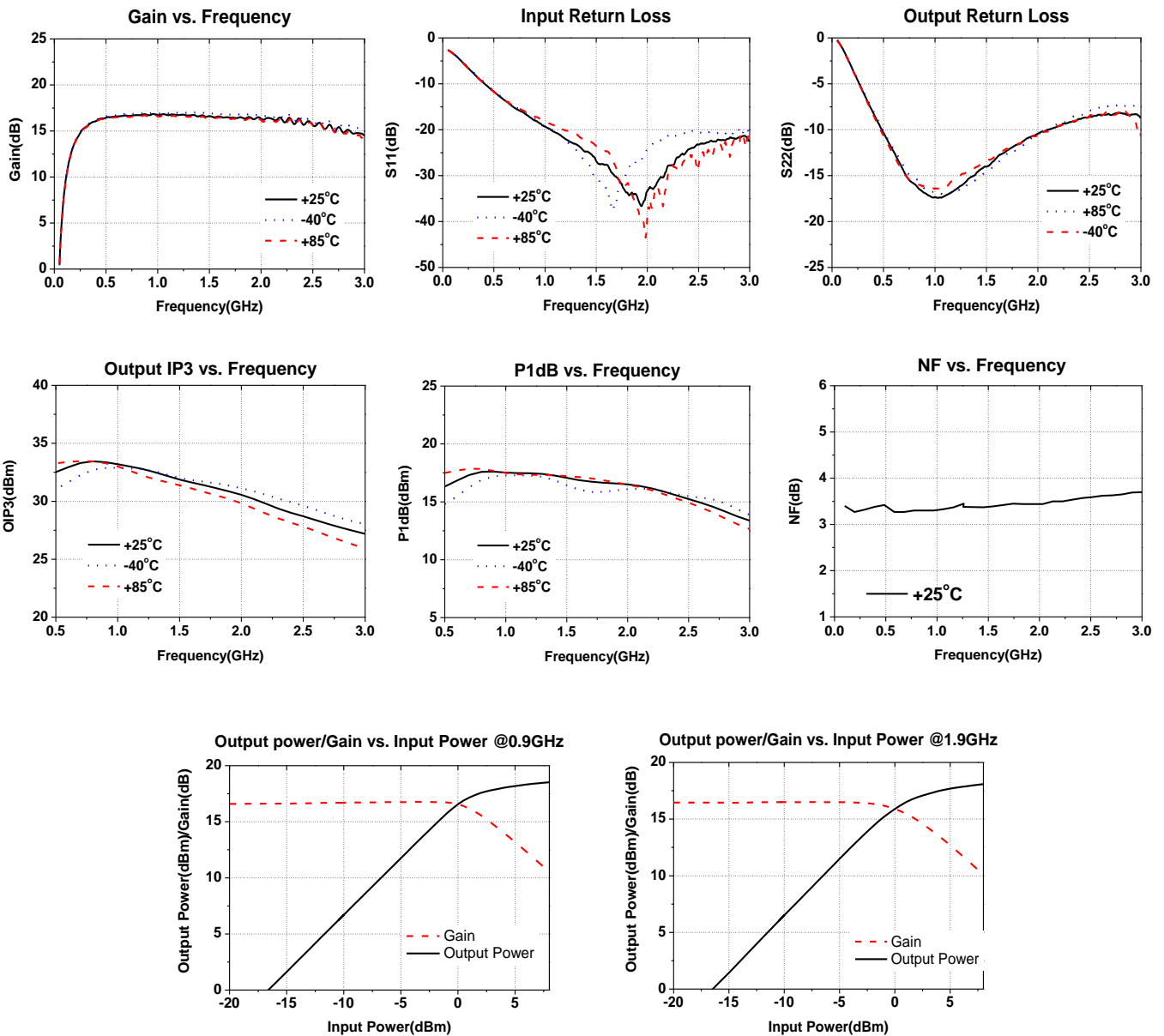

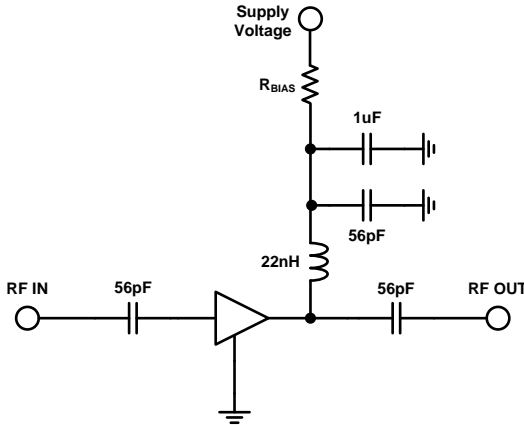
**1.9GHz Tuned Application Circuit**

**Recommended Bias Values**

Supply Voltage	R bias Value	Size
5.3 V	8.2 $\Omega$	0805
6 V	20 $\Omega$	0805
7 V	39 $\Omega$	1210
8 V	56 $\Omega$	1210
9 V	75 $\Omega$	2010
10 V	91 $\Omega$	2010
12 V	125 $\Omega$	2512

**Typical RF Performance for 50 - 500MHz Tuned Application Circuit**

Supply Bias Voltage = 6V, R(bias)= 20 ohm, Current=57mA

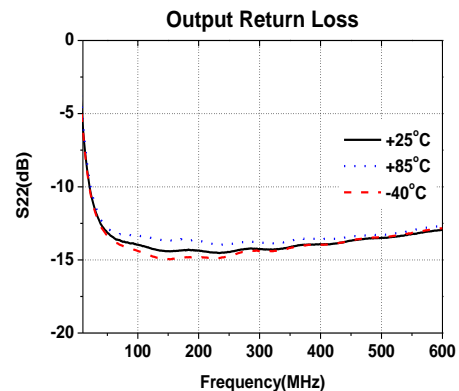
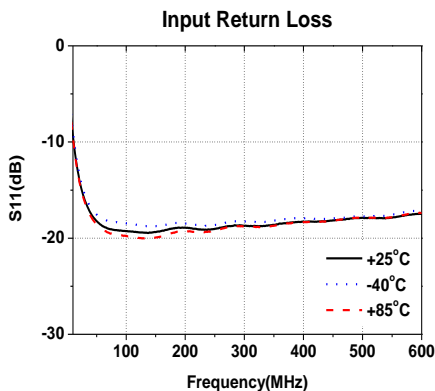
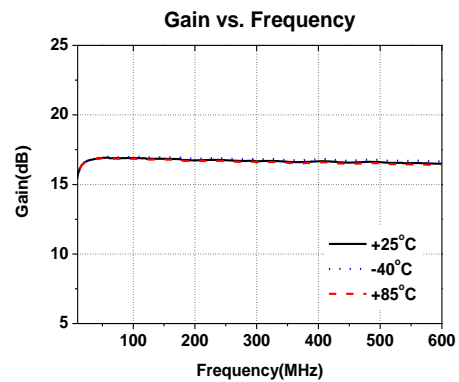
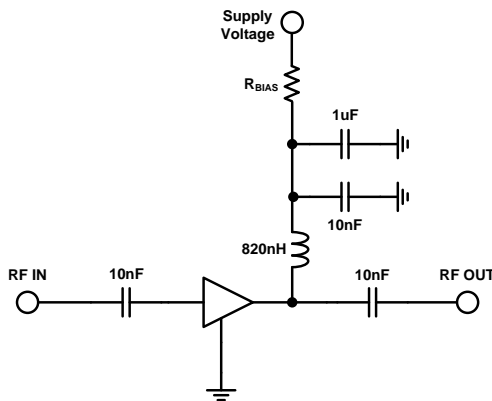
Frequency	MHz	75	125	300	500
S21 : Gain	dB	16.9	16.8	16.7	16.6
S11 : Input Return Loss	dB	-19	-19	-18	-17
S22 : Output Return Loss	dB	-13	-14	-14	-13
Output P1dB	dBm	18.5	18.3	18.2	18.0
Output IP3 @3dBm	dBm	33.5	33.5	33.2	32.3
Noise Figure	dB	3.2	3.2	3.2	3.3



### Absolute Maximum Ratings

Parameter	Rating	Unit
Supply Voltage	+8	V
Supply Current	200	mA
RF Power Input	10	dBm
Storage Temperature	-55 to +125	°C
Ambient Operating Temperature	-40 to +85	°C
Junction Temperature for >10 <sup>6</sup> hours MTF	187	°C

Operation of this device above any of these parameters may cause permanent damage.

### Lead-free /RoHS Compliant / Green SOT-89 Package Outline

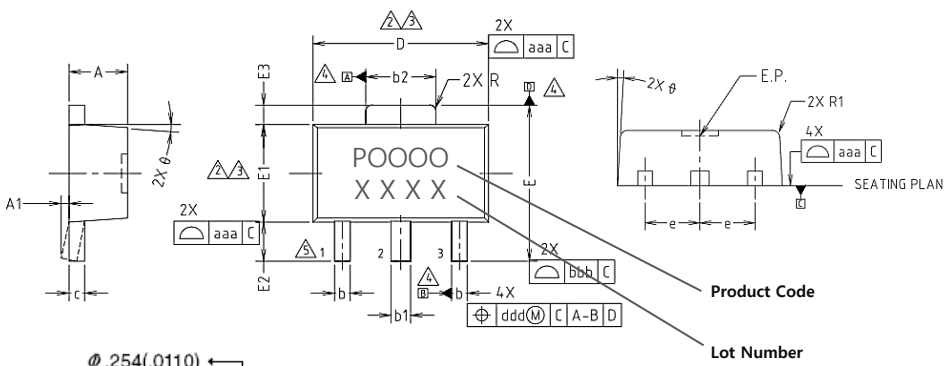

SYMBOL	MILLIMETERS			NOTE
	MINIMUM	NOMINAL	MAXIMUM	
A	1.40	1.50	1.60	
A1	0.00	—	0.10	
b	0.38	0.42	0.48	
b1	0.48	0.52	0.58	
b2	1.79	1.82	1.87	
c	0.40	0.42	0.46	
D	4.40	4.50	4.70	2,3
E	3.70	4.00	4.30	
E1	2.40	2.50	2.70	2,3
E2	0.80	1.00	1.20	
E3	0.40	0.50	0.60	
e	1.50 TYP.			
φ	4° TYP.			
R	0.15 TYP.			
R1	—	—	0.20	
SYMBOL	TOLERANCES OF FORM AND POSITION		NOTE	
aaa	0.15			
bbb	0.20			
ccc	0.10			
ddd	0.10			

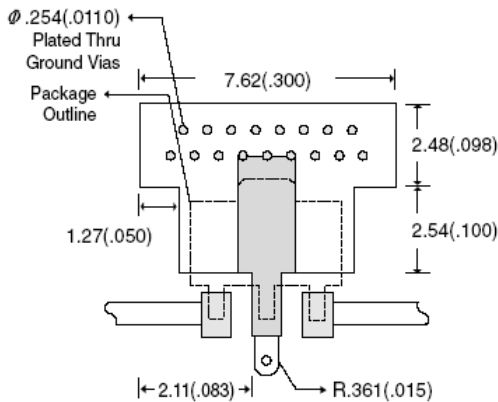

### ESD / MSL Ratings

1. ESD sensitive device. Observe Handling Precautions.
2. ESD Rating : Class 2(Passes at 2000V min.) Human Body Model (HBM), JESD22-A114
3. ESD Rating : Class IV (Passes at 1000V min.) Charged Device Model (CDM), JESD22-C101
4. MSL (Moisture Sensitive Level) Rating : Level 1 at +260°C Convection reflow, J-STD-020

### Evaluation Board Layout (4x4)

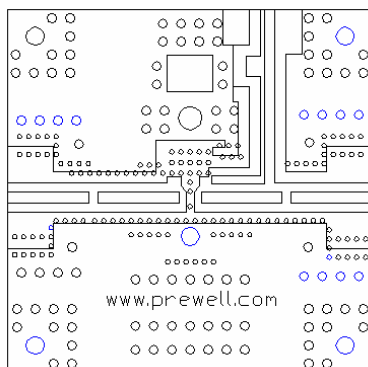

### Mounting Instructions

1. Use a large ground pad area with many plated through-holes as shown.
2. We recommend 1 oz copper minimum.
3. Measurement for our data sheet was made on 0.8mm thick FR-4 Board.
4. Add as much copper as possible to inner and outer layers near the part to ensure optimal thermal performance.
5. RF trace width depends on the board material and construction.
6. Add mounting screws near the part to fasten the board to a heatsink.

<http://www.prewell.com>