

Features

- ➔ DC - 4000MHz
- ➔ 20.5 dB Gain at 0.9GHz
- ➔ +20 dBm P1dB
- ➔ +38 dBm Output IP3
- ➔ Single Voltage Supply
- ➔ Lead-free / Green / RoHS-compliant SOT-89 Package

Applications

- ➔ Broadband Gain Block
- ➔ Mobile Infrastructure
- ➔ Cellular, PCS, GSM, GPRS, WCDMA, WiBro, WiMAX
- ➔ W-LAN / DMB / ISM
- ➔ CATV / DBS
- ➔ RFID / Fixed Wireless

Functional Diagram

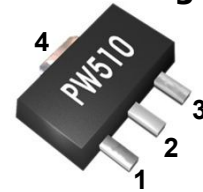

Function	Pin No.
RF IN	1
RF OUT / Bias	3
Ground	2,4

Description

The PW510 is a high performance InGaP HBT MMIC Amplifier and consists of Darlington pair amplifiers. The amplifier features high linear performance, wideband operation, and high reliability. The PW510 operates from a single voltage supply and requires only two DC-blocking capacitors, a bias resistor and an inductor for operation. The device is a general purpose buffer amplifier that offers high dynamic range in a low cost surface-mountable plastic SOT-89 packages.

Specifications

Symbol	Parameters	Units	Freq.	Min.	Typ.	Max.
S21	Gain	dB	75 MHz 900 MHz 1900 MHz 2300 MHz 3500 MHz		21.5 20.5 18.5 17.5 15.7	
S11	Input Return Loss	dB	75 MHz 900 MHz 1900 MHz 2300 MHz 3500 MHz		-27 -24 -18 -16 -13	
S22	Output Return Loss	dB	75 MHz 900 MHz 1900 MHz 2300 MHz 3500 MHz		-18 -25 -11 -9 -10	
P1dB	Output Power @1dB compression	dBm	75 MHz 900 MHz 1900 MHz 2300 MHz 3500 MHz		20 20 19 18 16.5	
OIP3	Output Third Order intercept	dBm	75 MHz 900 MHz 1900 MHz 2300 MHz 3500 MHz		38.5 38.0 35.0 33.5 30.5	
NF	Noise Figure	dB	75 MHz 900 MHz 1900 MHz 2300 MHz 3500 MHz		3.4 3.4 3.5 3.6	
V / I	Device voltage / current	V/mA			5.4/85	
Rth	Thermal Resistance	°C/W			65	
Tj	Junction Temperature	°C			120	

Test Conditions - T=25°C, Supply Voltage=+6V, Rbias=6.8ohm, 50ohm System, OIP3 measured with two tones at an output power of +3dBm/tone separated by 1MHz.

Typical RF Performance for 1.9GHz Tuned Application Circuit

Supply Bias Voltage = 6V, R(bias)= 6.8 ohm, Current= 85mA

Frequency	MHz	500	900	1500	1900	2300	3000
S21	dB	20.9	20.5	19.7	18.5	17.5	16.5
S11	dB	-14	-24	-24	-18	-16	-16
S22	dB	-14	-25	-14	-11	-9	-8
P1dB	dBm	20	20	20	19	18	17
OIP3	dBm	37.0	38.0	36.5	35.0	33.5	31.5
Noise Figure	dB	3.4	3.4	3.4	3.5	3.6	4.2

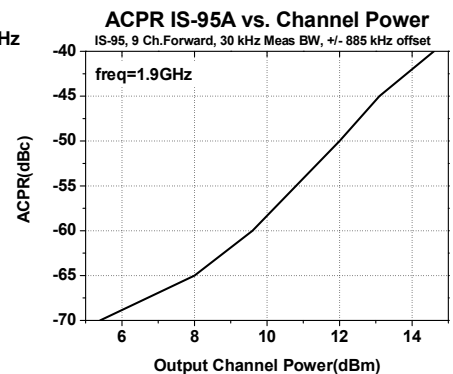
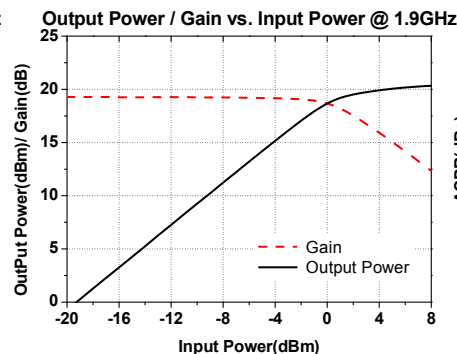
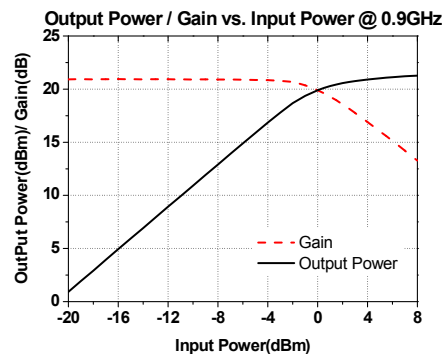
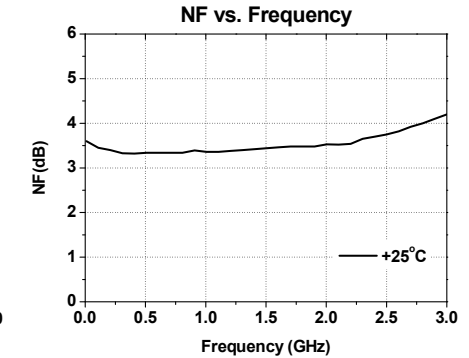
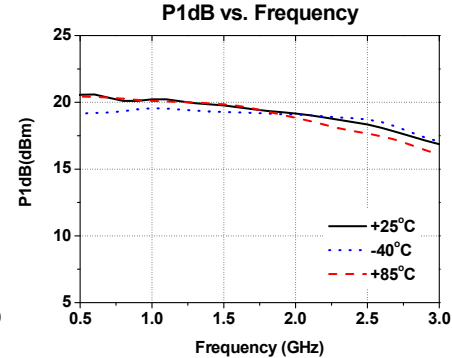
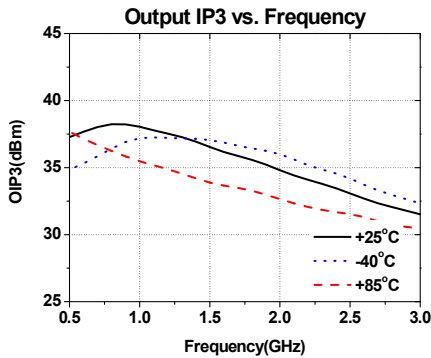
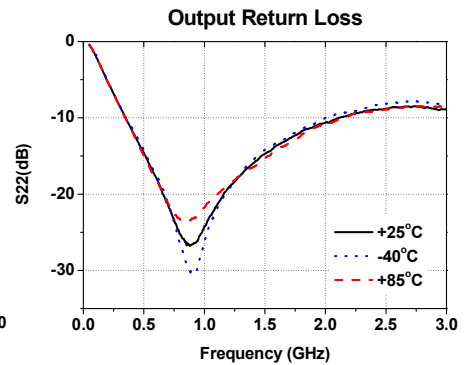
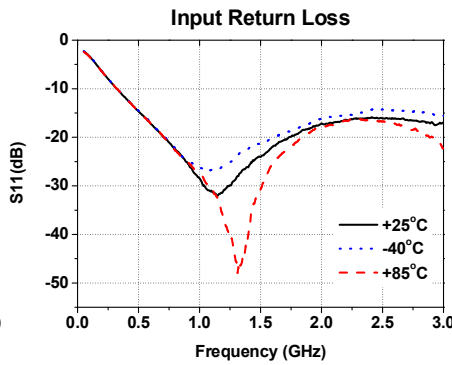
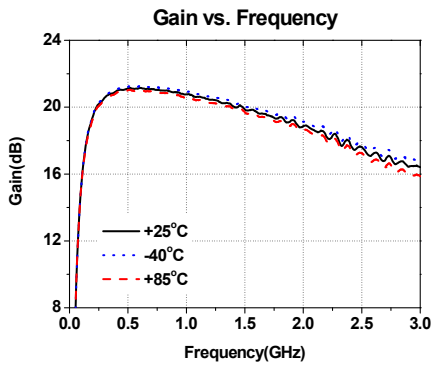

1.9GHz Tuned Application Circuit

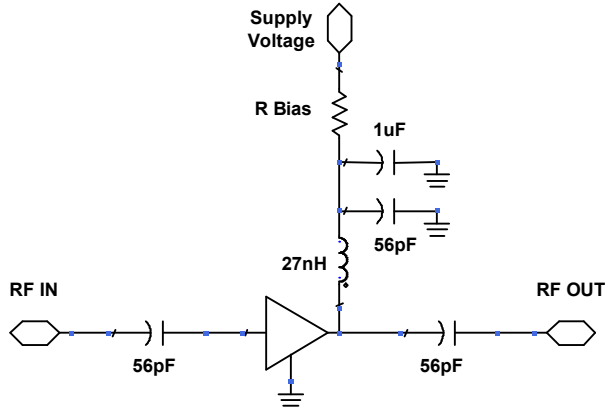

Recommended Bias Values

Supply Voltage	R bias Value	Size
6 V	6.8 Ω	0805
7 V	18.6 Ω	1210
8 V	30.4 Ω	1210
9 V	42.1 Ω	2010
10 V	53.9 Ω	2010
12 V	77.4 Ω	2512

Typical RF Performance for 50 - 500MHz Tuned Application Circuit

Supply Bias Voltage = 6V, R(bias)= 6.8 ohm, Current= 85mA

Frequency	MHz	75	125	300	500
S21 : Gain	dB	21.5	21.5	21.3	21.1
S11 : Input Return Loss	dB	-27	-35	-30	-25
S22 : Output Return Loss	dB	-18	-19	-18	-15
Output P1dB	dBm	20	20	20	20
Output IP3 @3dBm	dBm	38.5	38.5	37.5	37.0
Noise Figure	dB	3.4	3.4	3.4	3.4

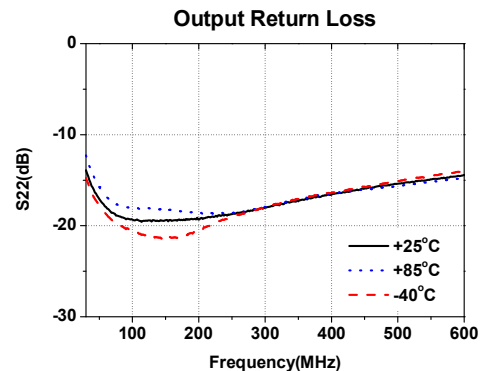
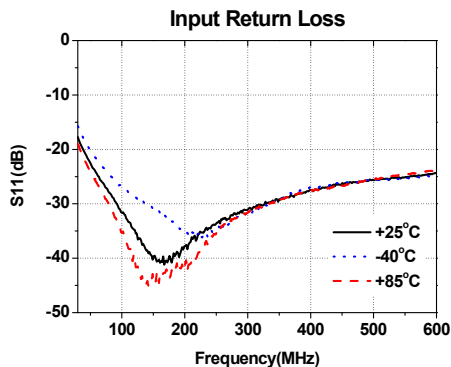
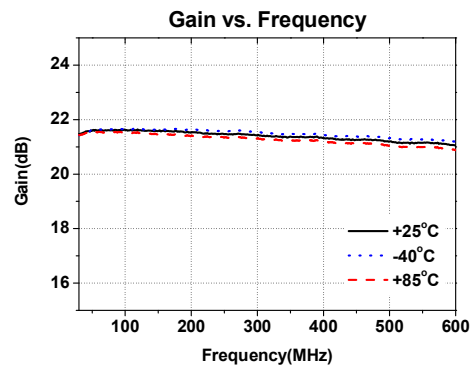
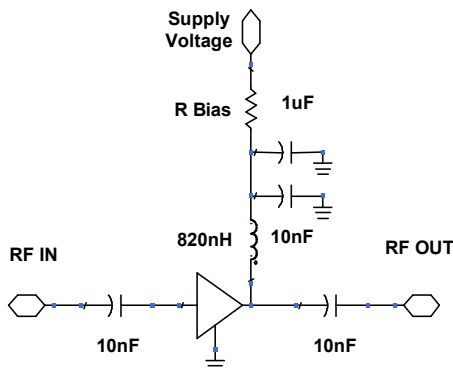

Typical RF Performance for 3500MHz Tuned Application Circuit
Supply Bias Voltage = 6V, R(bias)= 6.8 ohm, Current= 85mA

Frequency	MHz	3000	3500	4000
S21 : Gain	dB	16.4	15.7	13.2
S11 : Input Return Loss	dB	-15	-13	-7
S22 : Output Return Loss	dB	-8	-10	-10
Output P1dB	dBm	17.5	16.7	14.8
Output IP3 @3dBm	dBm	32.0	30.5	29.0

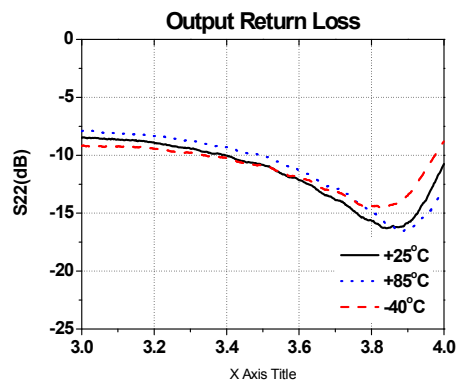
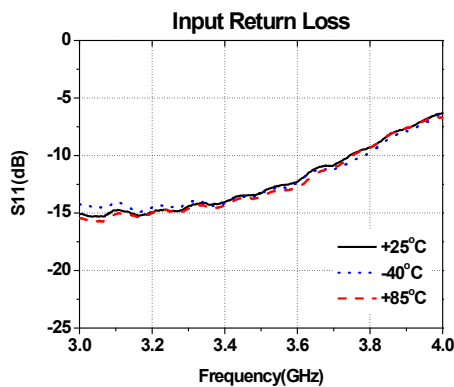
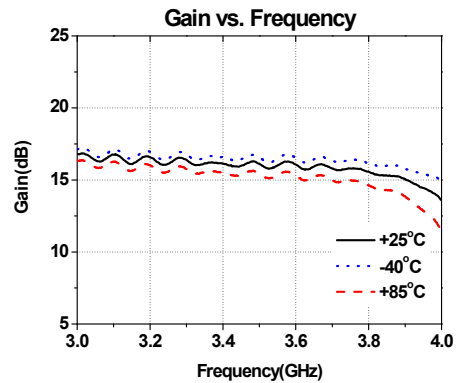
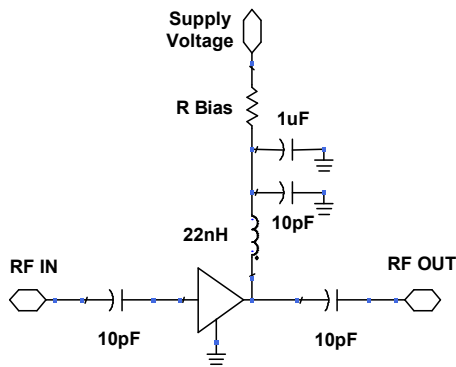

Typical RF Performance for 45 -1000MHz CATV Application(75Ω)⁽¹⁾

Frequency	MHz	50	450	870
S21 : Gain	dB	20.8	20.9	20.6
S11 : Input Return Loss	dB	-10	-15	-23
S22 : Output Return Loss	dB	-11	-15	-16
Output P1dB	dBm	20	20	20
Output IP3 ⁽²⁾	dBm	38	37	37
Composite Second Order, CSO ⁽³⁾	dBc	63	65	67
Composite Triple Beat, CTB ⁽³⁾	dBc	75	74	70
Cross Modulation, XMOD ⁽³⁾	dBc	74	71	71
Noise Figure	dB	3.5	3.4	3.4
Current	mA	85		

1. Test Conditions : T=25°C, Supply Voltage=+6V, Rbias=6.8ohm, 75ohm System
2. OIP3 measured with two tones at an output power of +5dBm/tone separated by 1MHz.
3. 132 channels, 50-870MHz, +18dBmV/channel flat loading

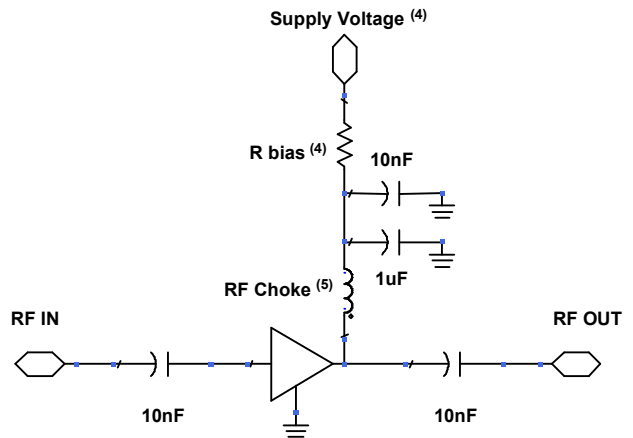

4. Supply Voltage and R bias are refer to 'Recommended Bias Values' on page 3.
5. RF Choke is about 8.3uH. We recommend that wire of 0.2 phi radius wind 7 turns on toroidal core(size:4.0x1.5x2.0)
6. Measurement for our data sheet was made on 1.6mm thick FR-4 Board. And 75 ohm microstrip line

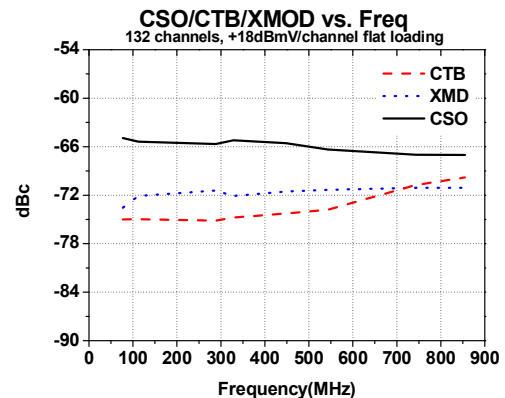
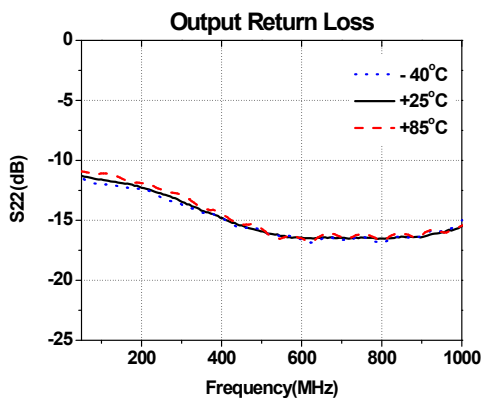
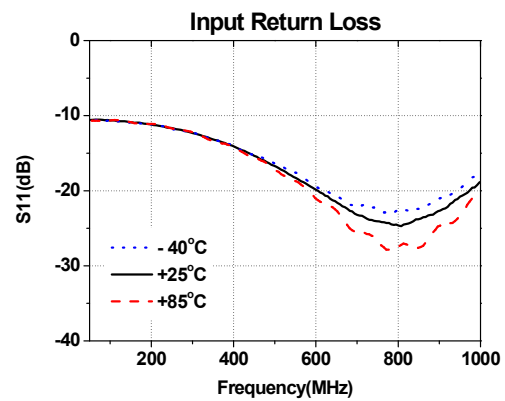
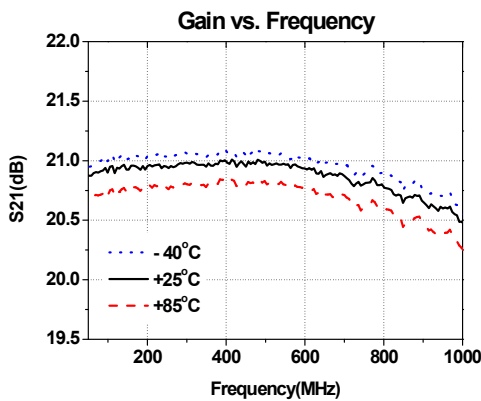

Absolute Maximum Ratings

Parameter	Rating	Unit
Supply Voltage	+8	V
Supply Current	200	mA
RF Power Input	10	dBm
Storage Temperature	-55 to +125	°C
Ambient Operating Temperature	-40 to +85	°C

Operation of this device above any of these parameters may cause permanent damage.

Lead-free / RoHS Compliant / Green SOT-89 Package Outline

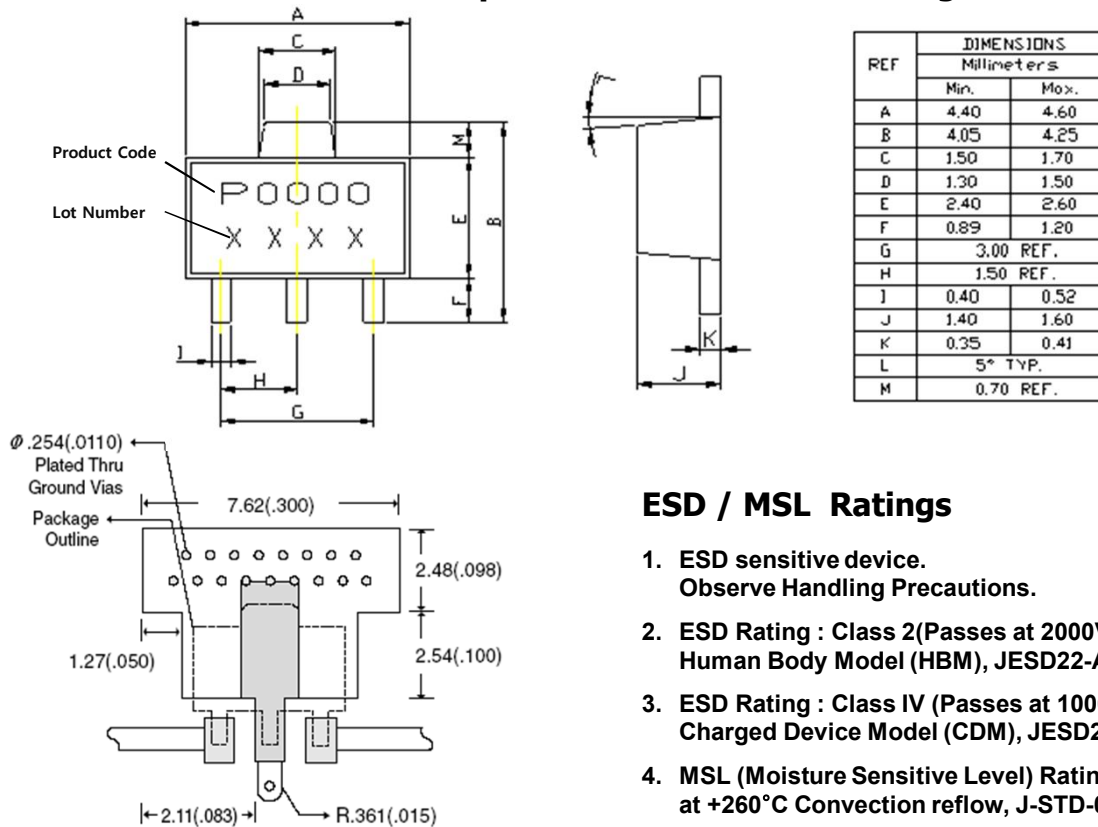

ESD / MSL Ratings

1. ESD sensitive device.
Observe Handling Precautions.
2. ESD Rating : Class 2(Passes at 2000V min.)
Human Body Model (HBM), JESD22-A114
3. ESD Rating : Class IV (Passes at 1000V min.)
Charged Device Model (CDM), JESD22-C101
4. MSL (Moisture Sensitive Level) Rating : Level 3
at +260°C Convection reflow, J-STD-020

Evaluation Board Layout (4x4)

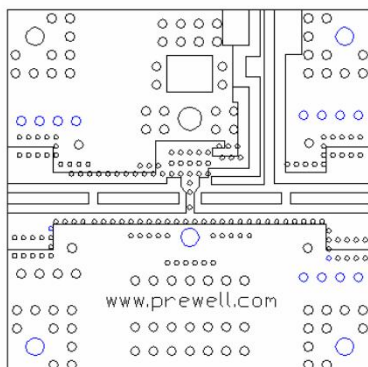

Mounting Instructions

1. Use a large ground pad area with many plated through-holes as shown.
2. We recommend 1 oz copper minimum.
3. Measurement for our data sheet was made on 0.8mm thick FR-4 Board.
4. Add as much copper as possible to inner and outer layers near the part to ensure optimal thermal performance.
5. RF trace width depends on the board material and construction.
6. Add mounting screws near the part to fasten the board to a heatsink.

<http://www.prewell.com>